

Part Number: PT347-53140

Kit Contents

Item #	Quantity Reqd.	Description
1	1	Convenience Net
2	1	Hardware Bag

Hardware Bag Contents

Item #	Quantity Reqd.	Description
1	2	T-Anchors
2	2	Weld Studs
3	2	O-Rings

Additional Items Required For Installation

Item #	Quantity Reqd.	Description

Conflicts

None

Recommended Tools

Personal & Vehicle Protection	Notes
None	
Special Tools	Notes
None	
Installation Tools	Notes
Plastic Trim Plug Removal Tool	SST# 00002-06001-01
Special Chemicals	Notes
None	

General Applicability

IS Sedan

Recommended Sequence of Application







Item #	Accessory

*Mandatory

Vehicle Service Parts (may be required for reassembly)

Item #	Quantity Reqd.	Description

Legend

	STOP: Damage to the vehicle may occur. Do not proceed until process has been complied with.
	OPERATOR SAFETY: Use caution to avoid risk of injury.
	CAUTION: A process that must be carefully observed in order to reduce the risk of damage to the accessory/vehicle and to ensure a quality installation.
	TOOLS & EQUIPMENT: Used in Figures calls out the specific tools and equipment recommended for this process.
	REVISION MARK: This mark highlights a change in installation with respect to previous issue.
	SAFETY TORQUE: This mark indicates that torque is related to safety.

Care must be taken when installing this accessory to ensure damage does not occur to the vehicle. The installation of this accessory should follow approved guidelines to ensure a quality installation.

These guidelines can be found in the "Accessory Installation Practices" document.

This document covers such items as:-

- Vehicle Protection (use of covers and blankets, cleaning chemicals, etc.).
- Safety (eye protection, rechecking torque procedure, etc.).
- Vehicle Disassembly/Reassembly (panel removal, part storage, etc.).
- Electrical Component Disassembly/Reassembly (battery disconnection, connector removal, etc.).

Please see your Toyota dealer for a copy of this document.

1. Installation of Cargo Net.

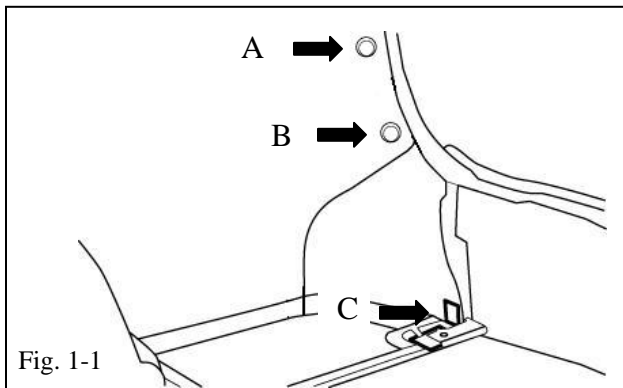

(a) Open trunk, locate trim plug location A & B and lower vehicle D-Ring anchor C on the passenger's side of the vehicle (Fig 1-1.)



(b) Using a plastic trim plug removal tool, remove trim plug A & B and discard trim plug A. (Fig. 1-2).

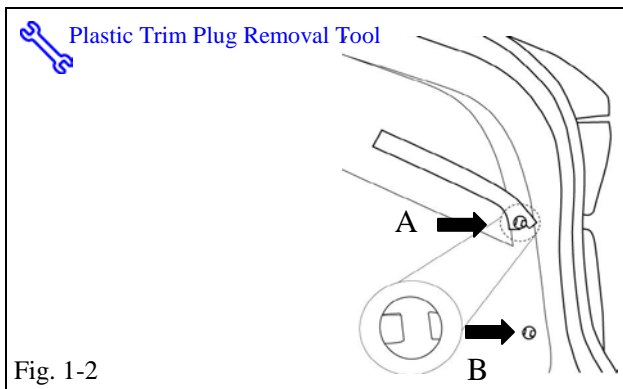

(c) Pull back trim panel and locate trim panel bracket at location A. Insert weld stud through hole in rear-side of bracket A and slide o-ring over the threaded stud shaft towards bracket to hold weld stud in place (Fig. 1-3). Push trim panel back in place ensuring weld stud threaded shaft is exposed through the hole in the panel. Install T-anchor onto weld stud and hand tighten to seat. Align T-anchor in the horizontal position.

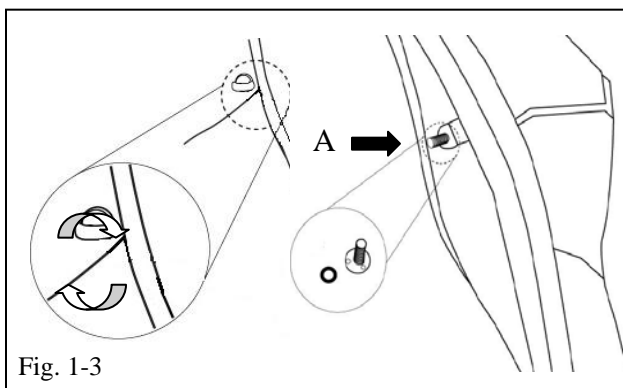

(d) Replace trim plug B and trim molding.

(e) Repeat steps (a) - (d) on driver's side of the vehicle.

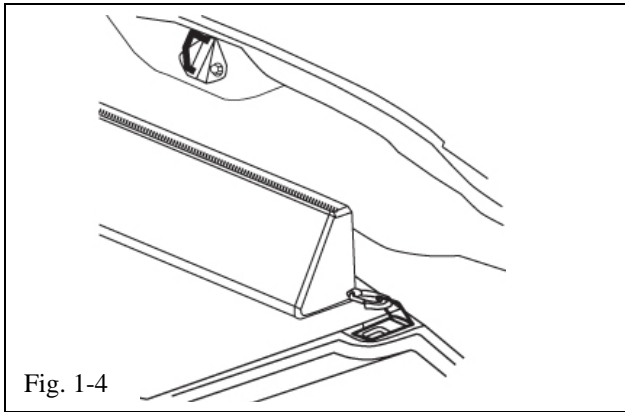

- (f) Attach clip at the bottom of the bag to the vehicle D-ring anchor as shown (Fig. 1-4).

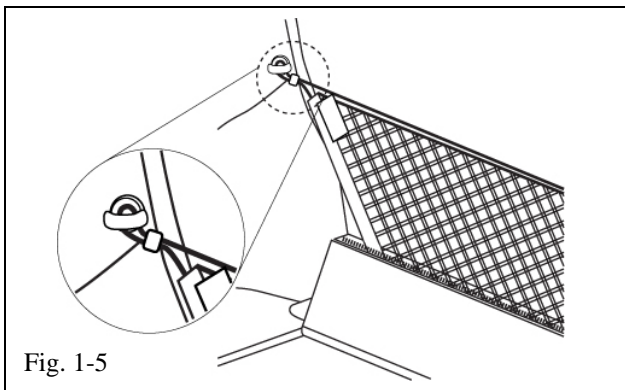

- (g) Un-zip bag and attach loop at the top of the net to the T-Anchor as shown (Fig. 1-5).
- (h) Repeat steps (f) - (g) for the opposite side of the vehicle.

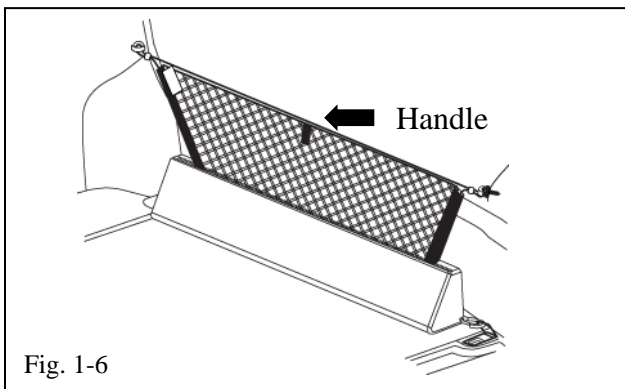

-  (i) Confirm completed assembly. Make sure the net handle is facing out toward the rear of the vehicle (Fig. 1-6).

Checklist - these points **MUST** be checked to ensure a quality installation.

<u>Check:</u>	<u>Look For:</u>
<p><u>Accessory Function Checks</u></p> <p><input type="checkbox"/> Confirm that the net is attached properly to the anchor points in the vehicle.</p>	<p>Make sure the loops are attached to the vehicle anchors at the top and bottom. The net handle should face out toward the rear of the vehicle.</p>
<p><u>Vehicle Function Checks</u></p> <p><input type="checkbox"/> Vehicle door operation</p> <p><input type="checkbox"/> Vehicle door trim molding</p>	<p>Confirm vehicle trunk door opens and closes without interference from Cargo Net.</p> <p>Ensure the door trim molding is replaced completely over the trunk trim and vehicle body.</p>
<p><u>Vehicle Appearance Check</u></p> <p><input type="checkbox"/> After accessory installation and removal of protective cover(s), perform a visual inspection.</p>	<p>Ensure no damage (including scuffs and scratches) was caused during the installation process. (For PPO installations, refer to TMS Accessory Quality Shipping Standard.)</p>